

For Residential Applications

Job Name _____

Contractor _____

Job Location _____

Approval _____

Engineer _____

Contractor's P.O. No. _____

Approval _____

Representative _____

IntelliFlow®

Series A2C-M1

Automatic Washing Machine Water Shutoff Valve with Leak Sensor

The Watts IntelliFlow® Automatic Washing Machine Shutoff Valve uses a state-of-the-art electronic control device that senses the washing machine current flow. When the washing machine is turned on, the controls detect the current flow to the washer, opening both hot and cold water inlet valves to allow water to flow to the washing machine. When the washing machine completes the full cycle the device senses the lack of current and closes the water inlet valves. These valves remain closed until the machine is used again. The IntelliFlow®'s automatic operation and floor mounted leak sensor protect against catastrophic water damage should a washing machine inlet hose burst while the machine is in use or unattended.

Features

- Easy installation
- Silent reliable operation
- Replaceable internal strainer screen
- The new IntelliFlow® Models A2C-M1 and A2C-WB-M1 also include a leak sensor. The water sensor is placed on the floor behind the washing machine. Upon detection of water at the sensor, the IntelliFlow® automatically shuts off the water supply to the washing machine. This provides an additional level of security, should a hose burst while the washing machine is in operation.

The contractor shall install an electrically actuated washing machine shutoff valve on the hot and cold water supply as indicated on the drawings. The electrically actuated washing machine valve shall be normally closed. The electrically actuated washing machine valve shall contain an integral electrical outlet capable of receiving a standard three-prong 120 VAC washing machine power cable. The valve shall actuate both the hot and cold water valves simultaneously upon detection of current flow at the integral electrical outlet which shall remain actuated until the detection of the interruption of current flow at the integral electrical outlet.

The valve shall be equipped with a 5 foot 14 AWG power cable. The valve shall be rated for 120 VAC, 60 Hz with a maximum standby current draw of less than one (1) ampere and a maximum appliance current draw of 15 amperes. The valve shall have a maximum pressure rating of 150psi (10.3 bar) and a maximum temperature rating of 180°F (82°C). The valve shall be UL listed for appliance controls. The electrically operated washing machine shutoff valve shall be equipped with a leak sensor. Upon detection of water at the leak sensor, current flow to both the hot and cold water valves shall be immediately interrupted. The valve shall be a Watts Regulator Company IntelliFlow® Model A2C-M1 surface mount unit or Model A2C-WB-M1 wall box unit.



Model A2C-M1
Patent # 6003536

Approvals



Model A2C-M1, A2C-WB-M1, A2T-M1, E164904 are ATNZ, ATNZ7 listed

Specifications

Mechanical

Maximum Pressure: 150psi (10.3 bar)
Maximum Temperature: 180°F (82°C)

Electrical

120 VAC, 15A, 60Hz
Cord: 5 ft.
Current draw (with appliance off): 20mA
Maximum appliance current rating: 15A
Circuit breaker requirement: 15 amp. GFI†

†Note: It is suggested that the electrical power source be ground fault protected.

How It Works

The Watts IntelliFlow® is equipped with a state-of-the-art electric current sensing device. When the washing machine is turned on, the IntelliFlow® senses the current flowing to the washing machine and opens the supply of water to washing machine. Upon completion of the full wash cycle, the washing machine shuts off cutting off the current. The IntelliFlow® senses this lack of current and closes both the hot and cold water supplies.

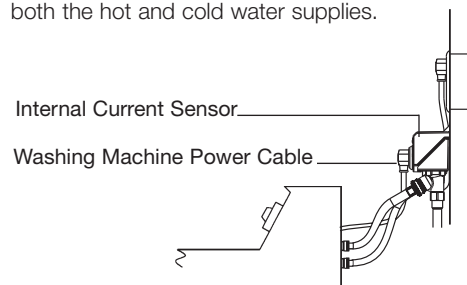

WATTS®

Watts product specifications in U.S. customary units and metric are approximate and are provided for reference only. For precise measurements, please contact Watts Technical Service. Watts reserves the right to change or modify product design, construction, specifications, or materials without prior notice and without incurring any obligation to make such changes and modifications on Watts products previously or subsequently sold.

Leak Sensor

Used in conjunction with the A2C-M1 or A2C-WB-M1, the leak sensor provides the maximum level of protection. Should water be detected at the leak sensor at any time, the water flow to the washing machine hoses will be cut off immediately. This protects against catastrophic water damage regardless of the operating cycle of the washing machine.

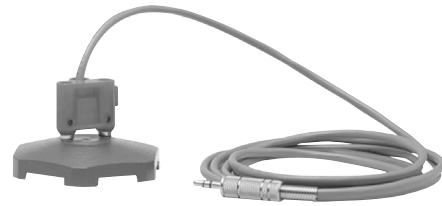

Leak Sensor

Optional Accessories

A2-IntelliTimer: A remote timer which allows the IntelliFlow® to be used with 240VAC powered appliances. Request literature ES/IS-A2-IntelliTimer.

Construction

The Watts No. A2C-M1 is equipped with 1/2" (13mm) sweat inlet adapters for both hot water and cold water supply tubing. It is supplied with two mounting tabs used to secure the valve to the wall for surface mount applications. The valve is enclosed in an engineered polymer enclosure.

Easy Installation

The Watts A2C-M1 IntelliFlow® comes equipped with 1/2" (13mm) sweat adapters to receive tubing. Either connection may be used for the hot or cold water supply because the A2C-M1 is equipped with long wearing Buna-N diaphragms for long life.

Water supply connections are 2 3/8" (60mm) on centers.

No electrical wiring is required. Simply plug the washing machine power cord into the IntelliFlow® and plug it to the standard 15A, GFI†, 120 volt outlet.

†Ground fault interrupter circuit

Typical Installations

The Watts IntelliFlow® can be installed in new construction or as an upgrade to existing installations.

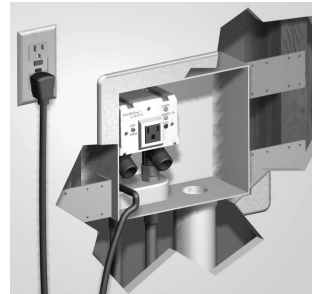

Model A2C-WB-M1
For Recessed Wall Mounting



Model A2C-M1
For surface mounting or retrofit installation
(See S-ES-A2-K)

Dimensions — Weights

Model A2C-M1

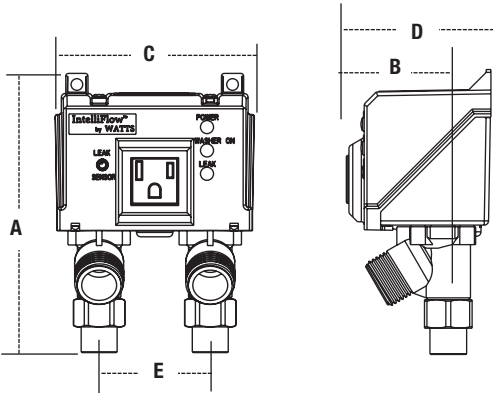

Model A2C-WB-M1

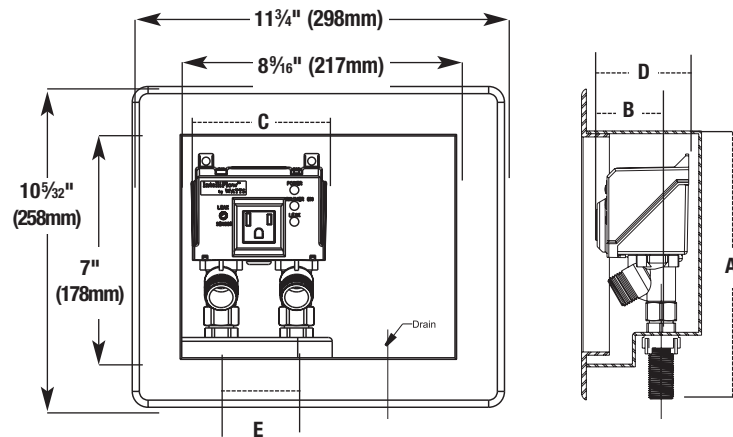

MODEL	SIZE (DN)		DIMENSIONS								WEIGHT			
	in.	mm	A	B	C	D	E			lbs.	kg			
A2C-M1	1/2	15	6	152	2 1/8	54	4 1/4	108	3 1/32	77	2 3/8	60	2.0	.9
A2C-M1-WB	1/2	15	8 1/2	216	2 1/8	54	4 1/4	108	3 1/32	77	2 3/8	60	3.5	1.6

CAUTION: Use of the Watts Automatic Washing Machine Valve outlet for appliances other than a washing machine is not recommended and voids the warranty.

Note: This valve cannot be used for 240 VAC, 3 phase appliances.

IMPORTANT: INQUIRE WITH GOVERNING AUTHORITIES FOR LOCAL INSTALLATION REQUIREMENTS



Water Safety & Flow Control Products

ES-A2C-M1 0729



USA: 815 Chestnut St., No. Andover, MA 01845-6098; www.watts.com
Canada: 5435 North Service Rd., Burlington, ONT. L7L 5H7; www.wattscanada.ca
© Watts Regulator Company, 2007