

Watts IntelliFlow™

Automatic Washing Machine Shutoff Valve

Model A2C-M1, A2C-WB-M1

Important! Read instructions completely before proceeding.

Note: This unit is not compatible with 240VAC powered washing machines or combination washer/dryers that are 240VAC powered. A Watts A2-IntelliTimer (purchased separately) may be used with the IntelliFlow™ with washing machines or washer/dryers that are 240VAC powered. (See page 5)



A2C-M1 IntelliFlow™

Patent Number 6,003,536 c UL US



***This valve requires a 120VAC, 60 Hz, 15 amp ground fault protected circuit.**

*Ground Fault Interrupter – A GFI circuit is not required for proper operation of the IntelliFlow™, but is strongly recommended as a safety device.



Surge Protection – Although a surge protector is not required for proper operation of the IntelliFlow™, it is strongly recommended, especially in areas where power surges or lightning strikes frequently occur.

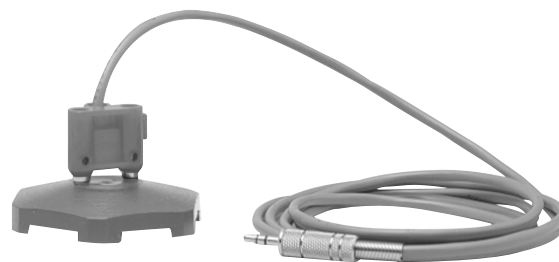

Leak Sensor

Operating Instructions

The Watts IntelliFlow™ Automatic Washing Machine Shutoff Valve is equipped with a state-of-the-art electric current sensing device. When the washing machine is turned on, the device senses current flow to the washing machine. This causes it to actuate its solenoid water valves, allowing water to flow to the washing machine. When the washing machine shuts off upon completion of the full wash cycle, the device senses the lack of current and closes the water valves. The IntelliFlow™ remains closed until the next time you turn the washer on.

The leak sensor provides additional protection from water damage while the washing machine is in operation. Water detected at the sensor results in immediate shut off of water flow to the washing machine hose.

By installing an IntelliFlow™, you are protecting your home from potential major water damage from a burst or leaking washing machine inlet hose.

Operating Specifications

Electrical Rating: 120VAC, 60 Hz

Circuit Breaker Requirements: 15A GFI*

Max. Appliance Current Rating: 15A

Current Draw: 20mA (with appliance off)

Electrical Cord: 6 ft. type SJT 14 AWG

Max. Temperature: 180°F (82°C)

Max. Pressure: 150psi (10.3 bar)

Valve Body: Reinforced Polysulfone

Rubber Goods: Buna-N, EPDM

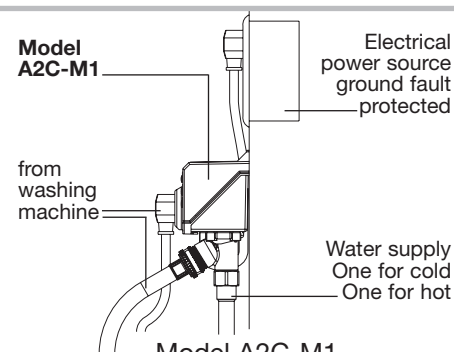

Model A2C-M1

1/2" solder connectors for exposed piping
Standardly furnished with 1/2" solder copper adapters. Either connection may be used for the hot or cold water supply.

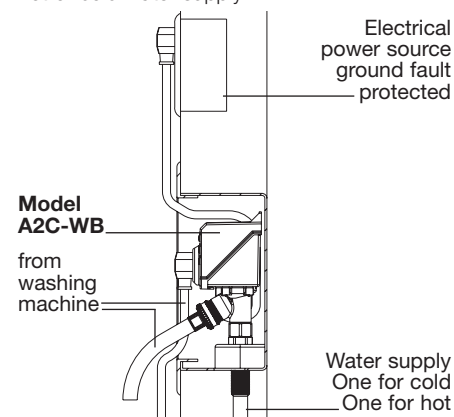

Model A2C-WB-M1

Includes wall mount box. Wall mount box has water inlet connection holes spaced 2 3/8" center to center. Furnished with 1/2" solder connectors. Either connection may be used for the hot or cold water supply.

WATTS®

***Ground Fault Interrupter** – A GFI circuit is not required for proper operation of the IntelliFlow™, but is strongly recommended as a safety device.

***Surge Protection** – Although a surge protector is not required for proper operation of the IntelliFlow™, it is strongly recommended, especially in areas where power surges or lightning strikes frequently occur.

Installing the A2C-M1 IntelliFlow™

WARNING:

Power MUST be off during installation or servicing of the valve!

IMPORTANT: Do not plug valve into supply circuit until completion of assembly.

For Vertical Installation Only!

1. Shut off electrical power supply.
2. Shut off both hot and cold water supply lines.
3. If retrofitting to an existing installation, disconnect the washing machine hoses from the existing shutoff valve(s).
4. Loosen the two (2) adapter nuts and remove both adapters from IntelliFlow™ valve body.
5. Place adapter nuts over piping prior to soldering adapters.
6. Solder adapters onto piping.
Note: Piping must be 2³/₈" on center (Figure 3).
7. Place O-rings on adapter grooves (Figure 3A).
8. Align and slip the valve body over adapters. Tighten adapter nuts.
Caution: Do not over-tighten nuts.
Caution: To avoid cross threading, check thread alignment.
9. Connect the washing machine hoses to the IntelliFlow™'s hot and cold water outlets.
10. Plug the washing machine into the IntelliFlow™'s electrical outlet.
Note: Appliance current rating must not exceed 15 amps.
11. Plug the IntelliFlow™'s power cord into a house electrical receptacle (Figure 4).
Note: The IntelliFlow™ requires a 120VAC, 60Hz, 15 amp ground-fault protected receptacle.*

IMPORTANT: The IntelliFlow™ will detect any current flow to the washing machine when the washing machine is off. The IntelliFlow™ must be calibrated to adjust the current flow threshold required to activate the shutoff valves. To calibrate the IntelliFlow™ see Calibration: (Startup) on page 4.

12. Turn on both hot and cold water supply lines, and check for leaks.
13. If there are no leaks, turn on the electrical power. Installation of the A2C-M1 IntelliFlow™ is now complete.

*Ground Fault Interrupter – A GFI circuit is not required for proper operation of the IntelliFlow™, but is strongly recommended as a safety device.

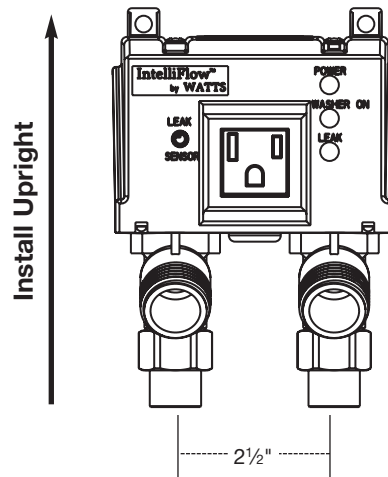

Figure 3

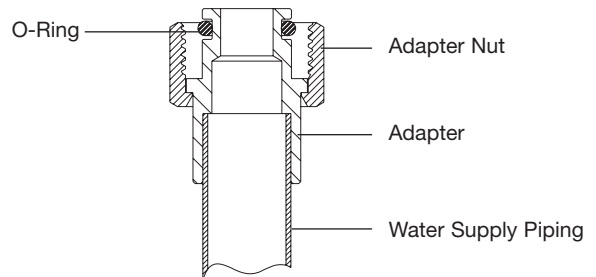

Figure 3A

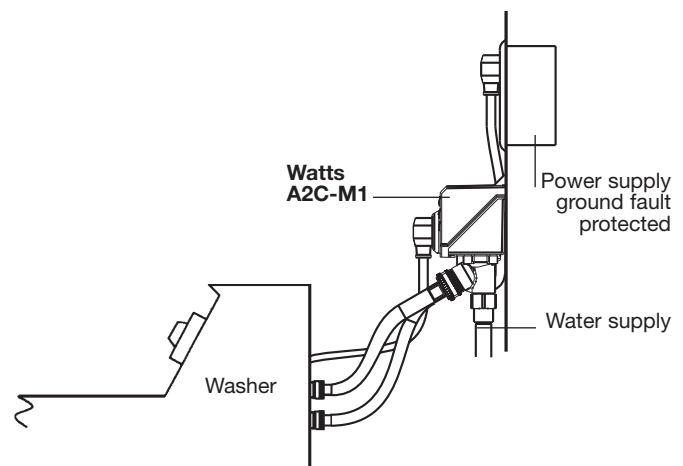

Figure 4

CAUTION:

Use of the Watts Automatic Washing Machine Valve outlet for appliances other than a washing machine is not recommended and voids the warranty.

IMPORTANT:

Do not plug valve into electrical supply circuit until you have completed installing the unit and reconnecting the water supply lines.

Installing the IntelliFlow™ Wall Box Unit (A2C-WB-M1)

WARNING:

Power MUST be off during installation or servicing of the valve!

IMPORTANT: Do not plug valve into supply circuit until completion of assembly.

For Vertical Installation Only!

1. Shut off electrical power supply.
2. Shut off both hot and cold water supply lines.
3. Remove trim plate (Figs. No.5 & 6) and set aside until you've completed wall finishing (painting, wall papering, paneling, etc.).
4. Install the four mounting tabs provided in slots on the sides of the wall box enclosure (Fig. No. 7).
5. Position the A2C-WB-M1 between the wall studs as shown in Fig. No. 7. Check that it is level and fasten the mounting tabs to the studs.
6. Remove drain plug knock out. Install drain piping and water supply piping to the appropriate IntelliFlow™ connection. Either IntelliFlow™ connection may be used for the hot or cold water supply.

Caution: Excessive heat from soldering can damage plastic components. Use a heat sink to prevent damage.
7. Place O-rings on adapter grooves (Figure No. 3A).
8. Align and slip the valve body over adapters. Tighten adapter nuts.

Caution: Do not over tighten nuts.

Caution: To avoid cross threading, check thread alignment.
9. Prior to installing wall materials, turn on water supply (both hot and cold) and test for leaks. Test drain piping for leaks.
10. Turn off water supply until you've completed installing wall materials.

Note: Installation must comply with local codes and ordinances. Inspection and approval of installation by local authorities may be required prior to installation of wall material. Check with local plumbing authorities for requirements.
11. Once you've finished the wall, install trim plate, connect washing machine water supply hoses to the IntelliFlow™ valve and to the washing machine.
12. Plug washing machine into the IntelliFlow™'s electrical outlet.

Note: Appliance current rating must not exceed 15 amps.
13. Insert the IntelliFlow™'s power cord into a house electrical outlet.

Note: The IntelliFlow™ requires a 120VAC, 60Hz, 15 amp ground-fault protected receptacle.*
14. Turn on both hot and cold water supply lines, and check for leaks.
15. If there are no leaks, turn on the electrical power. Installation of the IntelliFlow™ A2C-WB-M1 Wall Box Unit is now complete.

IMPORTANT: The IntelliFlow™ will detect any current flow to the washing machine when the washing machine is off. The IntelliFlow™ must be calibrated to adjust the current flow threshold required to activate the shutoff valves. To calibrate the IntelliFlow™ see Calibration: (Startup) on page 4.

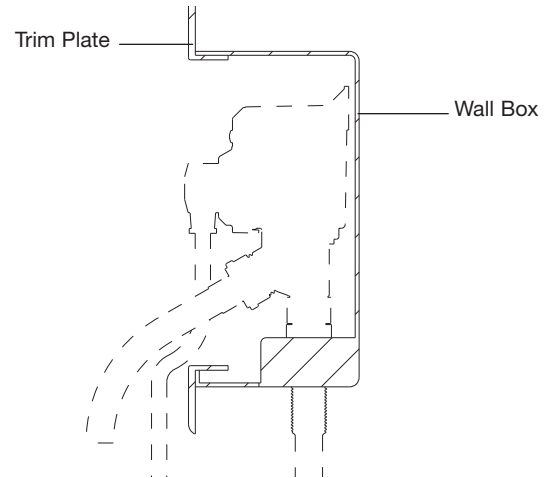

Figure 5
(side view)

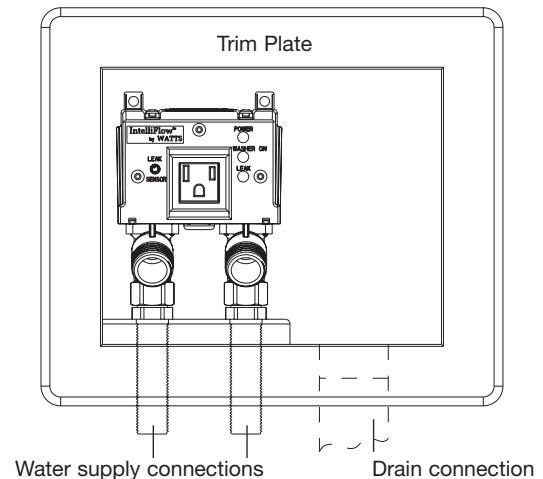

Figure 6
(front view)

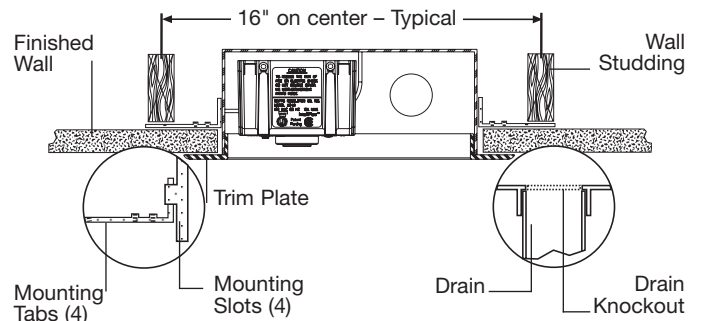

Figure 7
(top view)

*Ground Fault Interrupter – A GFI circuit is not required for proper operation of the IntelliFlow™, but is strongly recommended as a safety device.

Installing the Watts Model A2-LS Leak Sensor

Description:

The Watts Model A2-LS Leak Sensor plugs into the receptacle on the front panel of the Watts IntelliFlow™ Series A2C-M1 or A2-WB-M1. The base of the sensor is placed on the floor close to the washing machine. Upon detection of water at the sensor the IntelliFlow™ immediately shuts off the water supply to the washing machine hoses preventing catastrophic water damage.

Installation:

1. Insert the leak sensor contacts into the two holes on the top of the sensor base until the plug comes to a stop (Figure 2).
2. Place the sensor base on the floor behind the washing machine as close to the fill hoses as possible. Insure that the sensor base is lying flat with all feet in contact with the floor surface.
3. Insert the leak sensor plug (Figure 1) into the leak sensor receptacle on front panel (Figure 2).

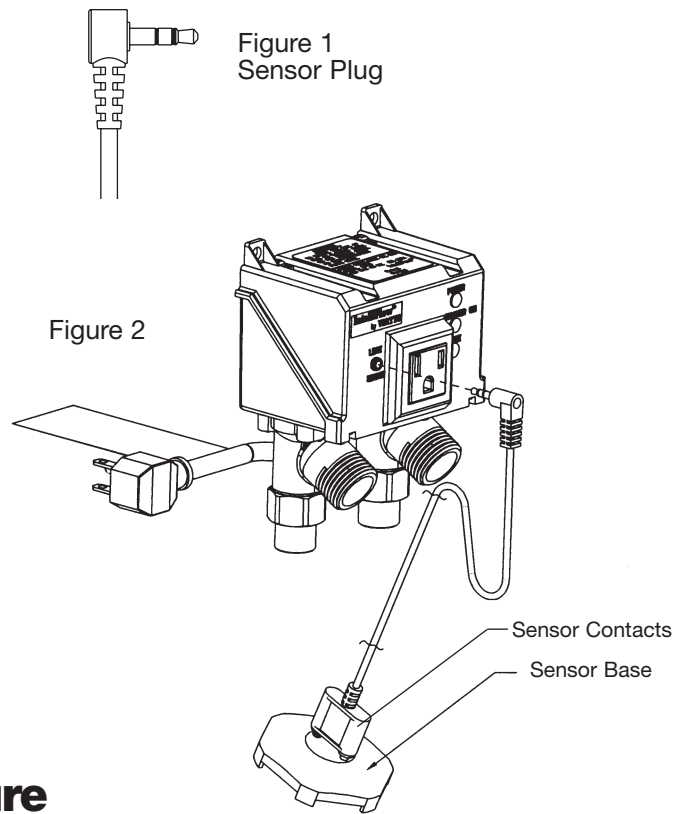

IntelliFlow™ Calibration Procedure

Some washing machine models include circuitry that causes a slight current draw at all times. These models when connected to the IntelliFlow™ can cause the water supply to be energized continuously (Yellow LED: on). Calibration allows the IntelliFlow™ to “learn” the off or standby current draw of the washing machine to prevent this condition.

Calibration: (Startup)

Calibration must be performed with the washing machine in the **off** position.

1. Before plugging in the IntelliFlow™ power cord into an electrical receptacle, ensure that the leak sensor plug (Figure 1) is unplugged from the IntelliFlow unit (Figure 2).
2. Plug the IntelliFlow™ power cord into an electrical receptacle. The green LED lamp should be on and stay on continuously. The red LED lamp should light for a few seconds then start to blink on and off, as an indication that the leak sensor is not plugged in.
3. Be sure that the washing machine is **off**. Plug the washing machine into the IntelliFlow™'s electrical outlet.
4. Plug the leak sensor plug into the leak sensor receptacle on the front panel. This will calibrate the IntelliFlow™ to the washing machine's off or standby position current draw. During the calibration sequence, the red LED lamp will remain lit for approximately 3-5 seconds. When calibration is complete the red LED lamp will blink four (4) times and shut off.

Calibration using IntelliTimer Accessory:

Calibration must be performed with the washing machine in the **off** position.

To calibrate the IntelliFlow™ for use with the IntelliTimer be sure that the washing machine is off and ensure that the power supply to the IntelliTimer is plugged into the IntelliFlow™ unit. Remove the leak sensor plug (Figure 1) from the receptacle, wait 5 seconds, then reinstall the sensor plug. During the calibration sequence, the red LED lamp will remain lit for approximately 3-5 seconds. When calibration is complete the red LED lamp will blink four (4) times and shut off.

Notes:

The IntelliFlow™ is designed to maintain its calibration in the event of a power failure. Should calibration ever be required, follow the procedure below.

Recalibration:

Calibration must be performed with the washing machine in the **off** position.

To recalibrate the IntelliFlow™, be sure that the washing machine is **off**. Remove the leak sensor plug (Figure 1) from the receptacle, wait 5 seconds, then reinstall the leak sensor plug. During the calibration sequence, the red LED lamp will remain lit for approximately 3-5 seconds. When calibration is complete the red LED lamp will blink four (4) times and shut off.

Accessories: Watts A2-IntelliTimer

The Watts A2-IntelliTimer is an optional accessory used in conjunction with the Watts IntelliFlow™ Automatic Washing Machine Shutoff Valve. It is a remote timer which allows the IntelliFlow™ to be used in applications where the washing machine or a combination washer/dryer is 240VAC powered. (The IntelliFlow™ is not compatible with 240VAC powered appliances). The timer initiates a two-hour cycle when the button is depressed.

The A2-IntelliTimer low voltage power supply is plugged into the IntelliFlow™ power outlet. The remote solid-state timer is installed in a location that is convenient to the user and connected to the low voltage power supply.

Activation of the push button on the timer causes current flow, which is detected by the IntelliFlow™. The IntelliFlow™ then actuates the solenoid valves, allowing water to flow to the washing machine. This also begins a timing sequence of two hours, which, upon its completion de-energizes the IntelliFlow™, shutting off the flow of water to the washing machine. The timing sequence can be interrupted by activating the push button a second time.

A Green LED is illuminated whenever the A2-IntelliTimer is energized.

Note: For calibration procedure see Page 4, "Calibration using IntelliTimer Accessory".

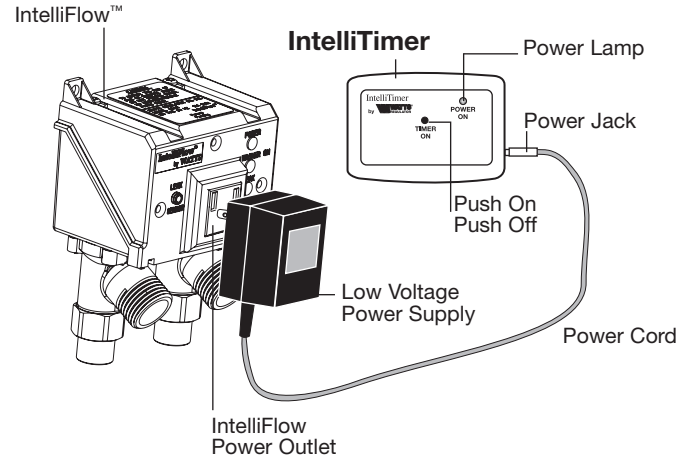
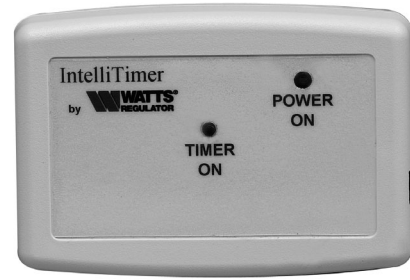

Typical Installation

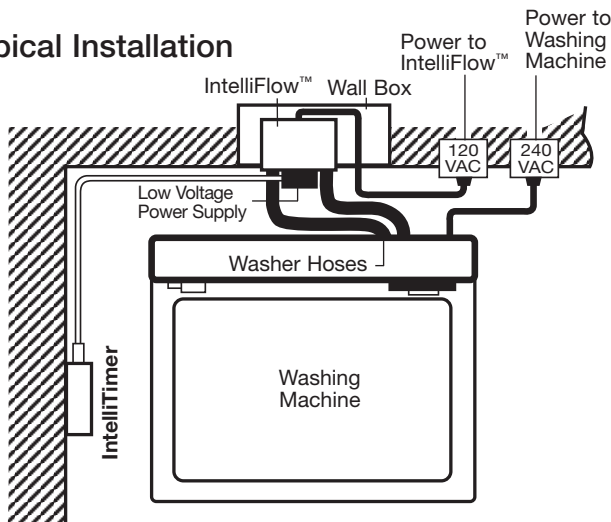

Troubleshooting Guide

PROBLEM

SOLUTION

1. No water flow from either hot or cold water supply hose:
GREEN LED: **OFF**

1. Plug IntelliFlow™ into electrical outlet.
2. Check electrical outlet for power (reset ground fault).

GREEN LED: **ON**
YELLOW LED: **OFF**
RED LED: **OFF / FAINT BLINK**

1. Plug washing machine into IntelliFlow™ and turn on washing machine.
2. Confirm operation of washing machine by plugging it into a separate electrical outlet.

GREEN LED: **ON**
YELLOW LED: **OFF**
RED LED: **ON**

1. Leak sensor has detected water.
2. Check for broken or leaking hoses.
3. Unplug IntelliFlow™ from electrical outlet, correct problem, then re-insert plug into outlet to reset valve.
4. Turn on washing machine.

GREEN LED: **ON**
YELLOW LED: **OFF**
RED LED: **BLINKING**

1. IntelliFlow™ internal timing circuit has timed out. Turn off washing machine to reset timing circuit.
2. Turn on washing machine.

2. No water flow from one hose - (either Hot or Cold):
GREEN LED: **ON**
YELLOW LED: **ON**
RED LED: **OFF / FAINT BLINK**

1. Service strainers on washing machine hoses.
2. Service strainers on IntelliFlow™ (see figure 1).
Caution prior to servicing strainers, first remove power to IntelliFlow™ by unplugging, then shut off both hot and cold water supply to IntelliFlow™.

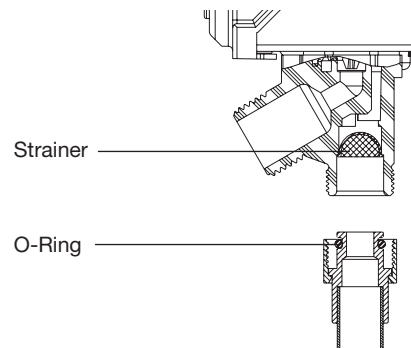

Figure 1

3. Yellow LED **Remains On**
GREEN LED: **ON**
YELLOW LED: **ON**
RED LED: **OFF / FAINT BLINK**

Some washing machine models include circuitry that causes a slight current draw at all times. These models when connected to the IntelliFlow™ can cause the water supply to be energized continuously (Yellow LED: ON). The IntelliFlow™ requires calibration, see page 4 for calibration instructions.

4. Unit feels warm:

This condition is normal. Internal operating temperatures may cause unit to feel warm to the touch.

5. Unit cycles ON/OFF:

Installation in a horizontal position can cause abnormal overheating of the unit which causes this cycling condition. Unit must be installed in an upright position as shown on pages 2 and 3.

Front Panel Status Indicators

GREEN LED: **ON:** Unit powered

This lamp is illuminated whenever the IntelliFlow™ is plugged into a powered wall outlet.

YELLOW LED: **ON:** Water supply Open.
OFF: Water Supply Closed.

This lamp is illuminated whenever the IntelliFlow™ senses current flow (the washing machine is turned on). It is off when the washing machine is turned off.

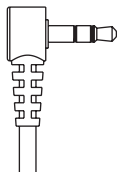

Sensor Plug

NOTE: Some washing machine models include circuitry that causes a slight current draw at all times. These models when connected to the IntelliFlow™ can cause the water supply to be energized continuously (Yellow LED: ON). The IntelliFlow™ requires calibration, see page 4 for calibration instructions.

RED LED: **ON:** Leak Sensed.

This lamp is illuminated when the leak sensor is installed and water has been detected at the sensor. The water supply to the washing machine hoses are interrupted when a leak is detected.

BLINKING: Unit Timed Out –

This lamp blinks whenever the internal timing circuit has timed out and has shut off the water supply to the washing machine hoses. Turning the washing machine Off then On will reset the timing circuit.

FAINT BLINK: (3-5 seconds) –

This condition indicates the leak sensor is unplugged. To provide the maximum level of protection, it is recommended that the leak sensor be installed at all times.

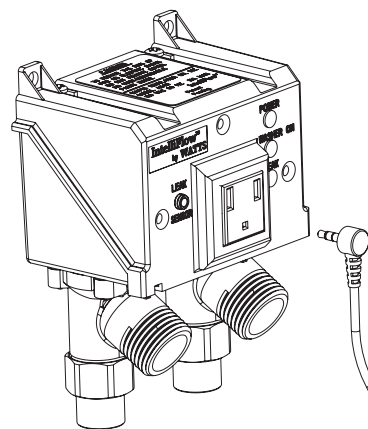

What is Surge Protection?

In many locations, changes in the AC voltage supply to the home by the electrical utility company can occur. Both lower voltage (brownouts) and high voltage (surges) can occur. Lightning strikes can also cause high voltage spikes to occur.

All electronic equipment is designed to operate properly within a voltage range. However, high voltage surges or spikes can damage sensitive circuitry within electronic equipment.

Surge protectors prevent voltage spikes from reaching electronic equipment.

What is Ground Fault Protection?

In many locations, an electrical differential between an electrical ground and a water pipe ground can exist. A person touching both grounds could receive a shock that may cause injury or death. A ground fault interrupter circuit (GFI) detects the differential and removes electrical power before injury can occur.

The IntelliFlow™ does not cause or change the electrical differential that exists.

IntelliFlow™ Retrofit Kit Options

IntelliFlow™

Retrofit Installation Kit KA2-BD Order No. 0004800

These mounting kits are specifically used to install the Watts Model A2C-M1 IntelliFlow™ automatic washing machine shutoff valve to existing drain valves.

If Your Current Installation Looks Like:



left or right drain

----- KA2-BD -----

Final Installation Will Look Like:

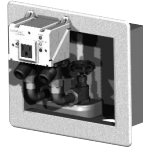

If Your Current Installation Looks Like:



center drain

----- KA2-BD -----

Final Installation Will Look Like:



IntelliFlow™

Retrofit Kit KA2-R Order No. 0004805

This kit is used to replace the following Watts IntelliFlow™ Models: A2-WB, A2C-WB, A2C-WB-M with the new IntelliFlow™ Model A2C-M1.

If Your Current Installation Looks Like:



----- or -----



----- KA2-R -----

Final Installation Will Look Like:



A2C-M1

Wall box style with #2 Style, A2-WB, A2C-WB or A2C-WB-M

IntelliFlow™

Retrofit Kit KA2-A Order No. 0004804

This kit is used to replace the following Watts washing machine shutoff valves: the wall mounted Watts Models #2 Duo-Cloz valve and the wall mounted IntelliFlow™ Models: A2, A2C, A2C-M with the new Watts IntelliFlow™ Model A2C-M1.

If Your Current Installation Looks Like:



----- or -----



----- KA2-A -----

Final Installation Will Look Like:



A2C-M1

Wall box style with #2 Style, A2, A2C or A2C-M

CALIFORNIA PROPOSITION 65 WARNING

WARNING: This product contains chemicals known to the State of California to cause cancer and birth defects or other reproductive harm. (California law requires this warning to be given to customers in the State of California.)

For more information: www.watts.com/prop65

Limited Warranty: Watts Regulator Co. (the "Company") warrants each product to be free from defects in material and workmanship under normal usage for a period of one year from the date of original shipment. In the event of such defects within the warranty period, the Company will, at its option, replace or recondition the product without charge.

THE WARRANTY SET FORTH HEREIN IS GIVEN EXPRESSLY AND IS THE ONLY WARRANTY GIVEN BY THE COMPANY WITH RESPECT TO THE PRODUCT. THE COMPANY MAKES NO OTHER WARRANTIES, EXPRESS OR IMPLIED. THE COMPANY HEREBY SPECIFICALLY DISCLAIMS ALL OTHER WARRANTIES, EXPRESS OR IMPLIED, INCLUDING BUT NOT LIMITED TO THE IMPLIED WARRANTIES OF MERCHANTABILITY AND FITNESS FOR A PARTICULAR PURPOSE.

The remedy described in the first paragraph of this warranty shall constitute the sole and exclusive remedy for breach of warranty, and the Company shall not be responsible for any incidental, special or consequential damages, including without limitation, lost profits or the cost of repairing or replacing other property which is damaged if this product does not work properly, other costs resulting from labor charges, delays, vandalism, negligence, fouling caused by foreign material, damage from adverse water conditions, chemical, or any other circumstances over which the Company has no control. This warranty shall be invalidated by any abuse, misuse, misapplication, improper installation or improper maintenance or alteration of the product.

Some States do not allow limitations on how long an implied warranty lasts, and some States do not allow the exclusion or limitation of incidental or consequential damages. Therefore the above limitations may not apply to you. This Limited Warranty gives you specific legal rights, and you may have other rights that vary from State to State. You should consult applicable state laws to determine your rights. **SO FAR AS IS CONSISTENT WITH APPLICABLE STATE LAW, ANY IMPLIED WARRANTIES THAT MAY NOT BE DISCLAIMED, INCLUDING THE IMPLIED WARRANTIES OF MERCHANTABILITY AND FITNESS FOR A PARTICULAR PURPOSE, ARE LIMITED IN DURATION TO ONE YEAR FROM THE DATE OF ORIGINAL SHIPMENT.**



Water Safety & Flow Control Products

USA: 815 Chestnut St., No. Andover, MA 01845-6098; www.watts.com

Canada: 5435 North Service Rd., Burlington, ONT. L7L 5H7; www.wattscanada.ca